

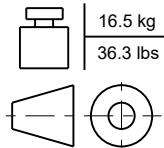

Rotating element • Elemento rotante • Drehelement • Élément tournant • Elemento de giro • 出旋轉元件

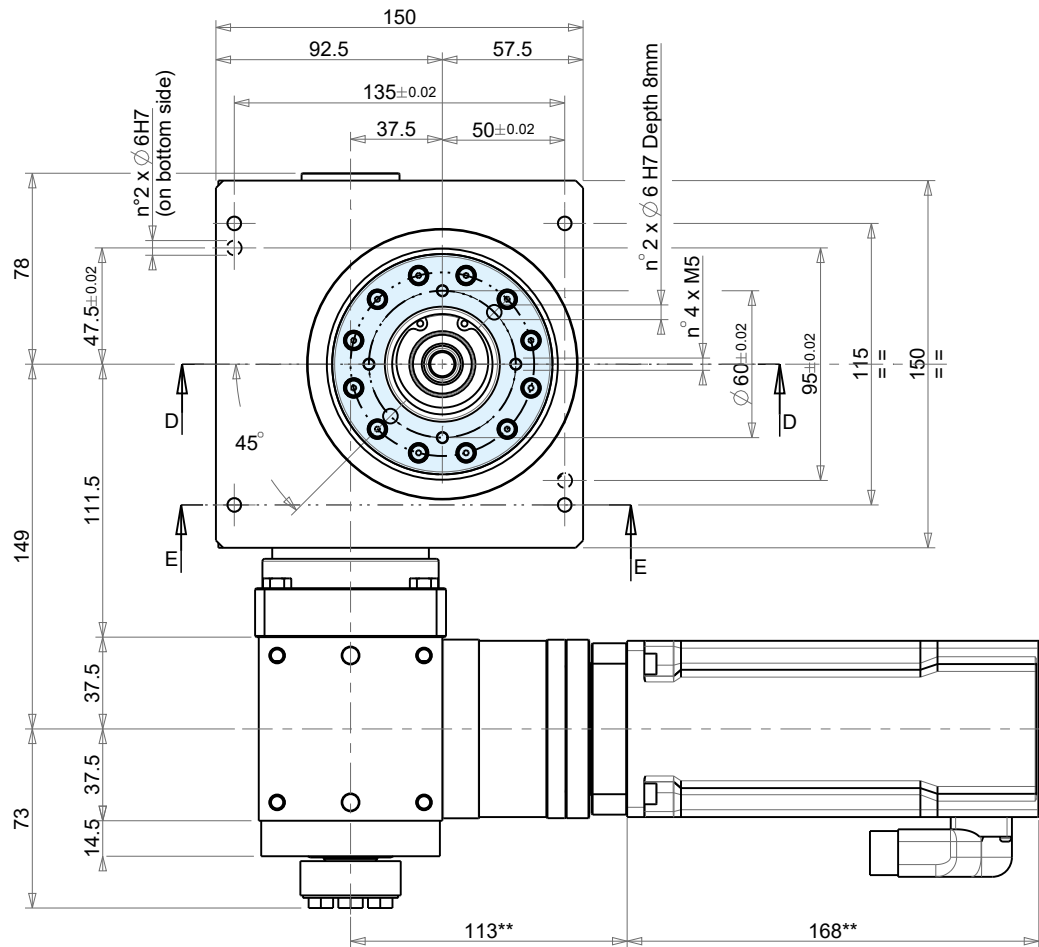
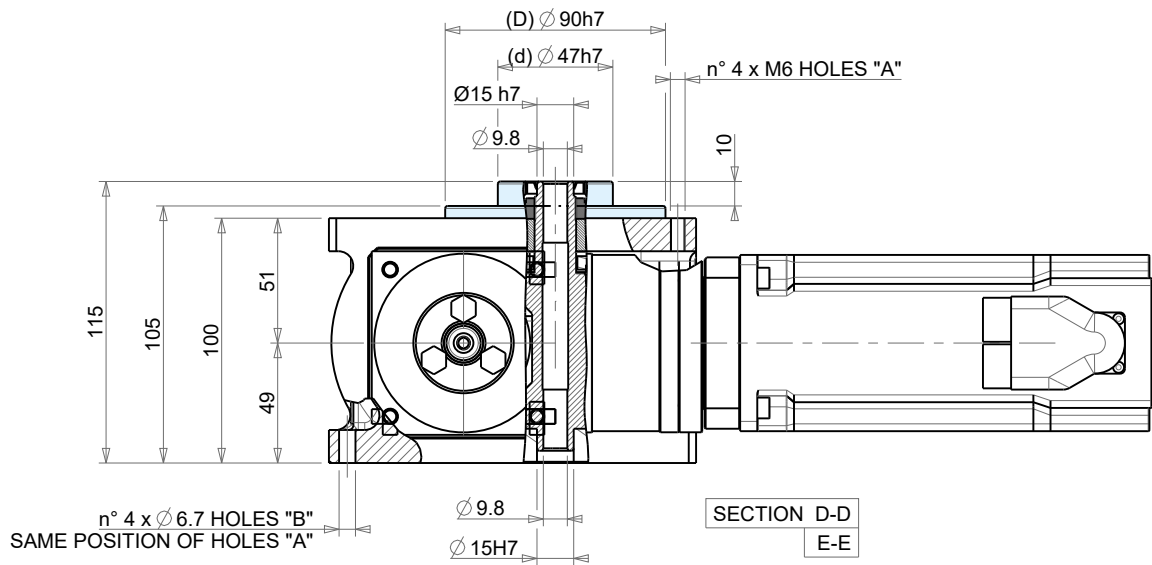

** = Dimension with servomotor Beckhoff - AM8531xx00

ITF 75	Reference Riferimento Bezug Référence Referencia 参考	Concentricity Concentricità Konzentrität Concentricité Concentricidad 同心度	Planarity Planarità Planheit Planéité Planaridad 平面度	Accuracy Precisione Teilgenauigkeit Précision Precisión 精度	Threaded holes position Posizione fori filettati Löcherposition Position des trou taraudé Posición orificios roscados 螺纹孔位置精度	Tolerance in compliance with Tolleranze secondo Toleranzen gemäß Tolérances selon Tolerancias con arreglo a 公差符合
				Standard		
	d	± 0.015 mm				
	D		± 0.015 mm			
	Rp			± 0.031°		
						UNI - ISO 2768-1 EN 22768-1



Unit		IT 75-12	
Total ratio		60 :1	
Max. rotary diameter		600 mm	
Max. output torque		53 N m	
Max. Application Inertia		3.60 kg m ²	
Internal inertia @ motor shaft		0.000535 kg m ²	
t _{360°}		1.39 s	
Max motor speed		6 000 min ⁻¹	
Max acceleration		14.71 rad/s ²	
Rated motor torque (max)		1.33 N m	
Gearbox code		ATB-FC075 1:5	APEX
Servo code		AM8531-xD00	Beckhoff

